

GREEN PRODUCT

REV.	ECN. NO.	LOCATIONS	DESCRIPTION	DATE	DESIGN
A0			INITIAL RELEASE	04/18'24	龚帆

A
B
C
D
E

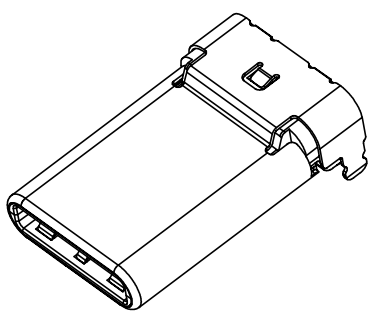
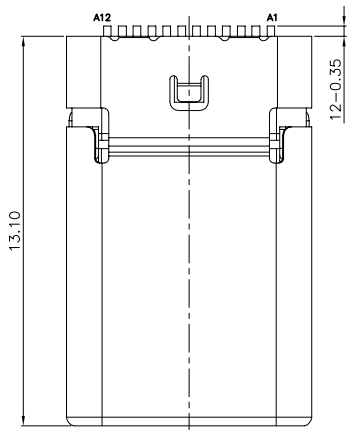

A1	GND	B12	GND
A2	TX1+	B11	RX1+
A3	TX1-	B10	RX1-
A4	VBUS	B9	VBUS
A5	CC	B8	SBU2
A6	D+	B7	
A7	D-	B6	
A8	SBU1	B5	VCONN
A9	VBUS	B4	VBUS
A10	RX2-	B3	TX2-
A11	RX2+	B2	TX2+
A12	GND	B1	GND
PIN	SIGNAL NAME	PIN	SIGNAL NAME

NOTE:
 1. MECHANICAL:
 1-1.MATING FORCE: 0.5~2.0Kgf
 1-2.UMMATING FORCE: Initial: 0.8~2.0Kgf
 After 10,000 cycles: 0.6~2.0Kgf
 1-3.FREQUENCE:500±50 CYCLES/HOUR,10000 CYCLES;
 2. ELECTRICAL CHARACTERISTICS:
 2-1. CURRENT RATING: 5.00 A for VBUS, 1.25 A for VCONN
 0.25 A FOR OTHER PINS
 2-2. INITIAL CONTACT RESISTANCE:40mΩ Max.
 2-3. INSULATION RESISTANCE:100MΩ MIN
 2-4. WITHSTANDING VOLTAGE:100V AC,1 MINUTE;
 3. ENVIRONMENTAL
 TEMPERATRUE RANGE: -25°C TO +85°C.
 4. PART NO. DESCRIPTION:

TC N 4 24 X - 4 1 -5 0 -069
 SHELL PLATED N: Ni
 PLATED ON CONTACT AREA
 B: Contact area: Au 1u" Min.
 E: Contact area: Au 3u" Min.
 D: Contact area: Au 15u" Min.
 C: Contact area: Au 30u" Min.
 0:NO MARK
 5:REEL
 HOUSING COLOUR 1:BLACK
 HOUSING MATERIAL 4:LCP

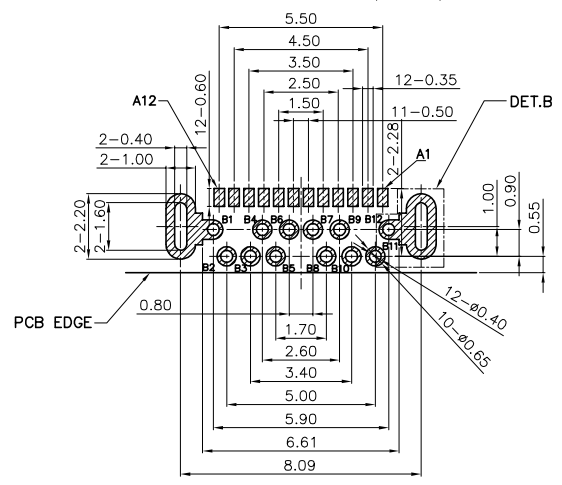
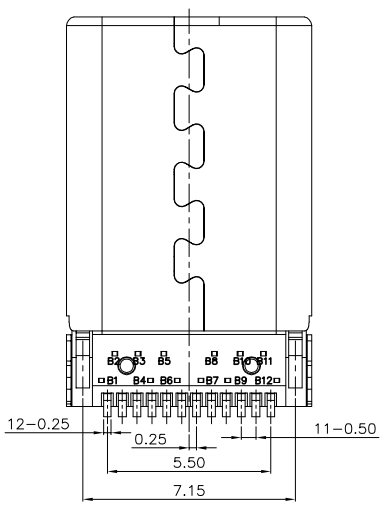
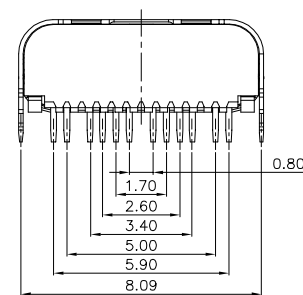
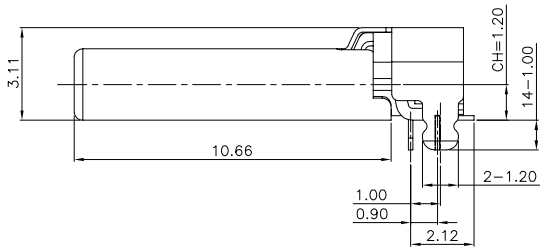
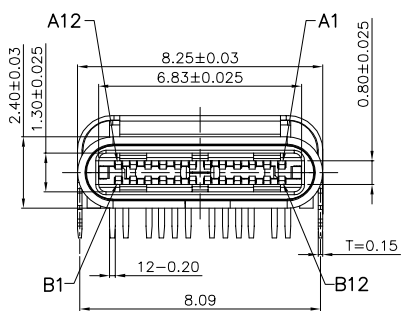

RCOMMENDED P.C.B
 TOLERANCE=±0.05(TOP VIEW)

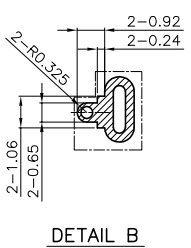

ITEM	PART NAME	Q'TY	MATERIAL	FINISH
1	INSULATOR	1	THERMOPLASTIC	Black, UL94V-0
2	CONTACT	24	HIGH CONDUCTIVITY COPPER	Contact area:Gold plated over Ni. DIP Solder area:Matte Tin plated over Ni. SMT Solder area:Matte Tin plated over Ni.
3	SHELL	1	STAINLESS STEEL	Ni plated over all
4	EMI SPRING	2	STAINLESS STEEL	CLEAN
5	MID-PLATE	1	STAINLESS STEEL	Ni plated over all

INTENDED USE	UNIT		東莞康祥電子有限公司 KANXIAN DONG GUAN KANG XIANG ELECTRON CO.,LTD.
PART NO. TCN424X-41-50-069	FINISH		
TOLERANCES .X ± 0.35 X.± 2° .XX± 0.25 X.X'± 1.5°	SEE NOTE	APPD:	TITLE: TYPE-C PLUG STANDARD DIP+SMT 24P CH=1.20 L=13.10
	SEE NOTE	CHKD:	FILE NO.
		DR:	REV. AO
		龚帆 04/18'24	SCALE 1/1 SHEET 1 OF 1